

THIS DRAWING IS UNPUBLISHED. RELEASED FOR PUBLICATION
 © COPYRIGHT - By - ALL RIGHTS RESERVED.

LOC	DIST	REVISIONS					
HB	-	P	LTR	DESCRIPTION	DATE	DWN	APVD
		F		ADD "VDE" RATING ECO-09-021062	17Sep2009	YS.H	BH.Y
		G		CHANGE LOGO & ADD LINE IDENTIFICATION ECO-12-003498 ADD CCC SYMBOL P-11-003756	02Nov2012	HYS	YBH

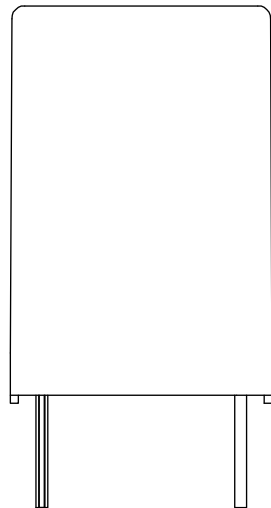

CONNECTION DIAGRAM (BOTTOM VIEW)

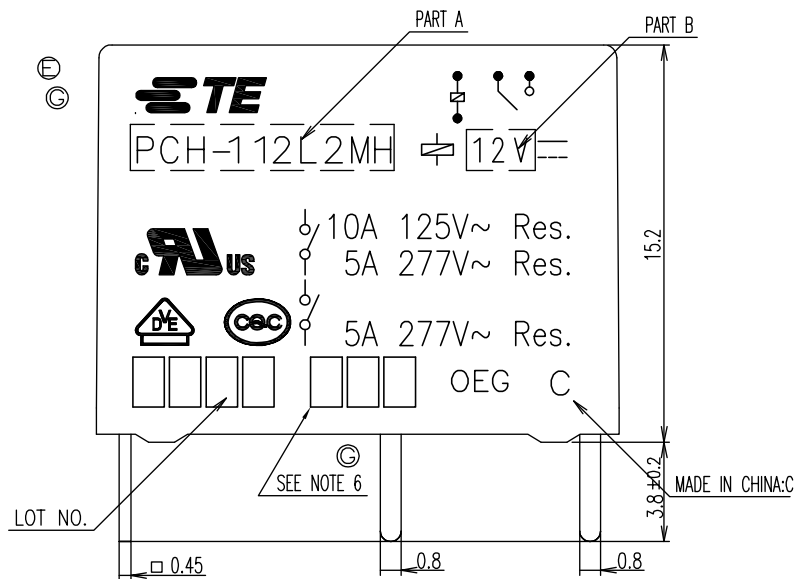
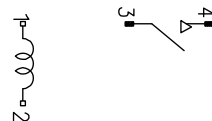

DRILLING DIAGRAM (BOTTOM VIEW)

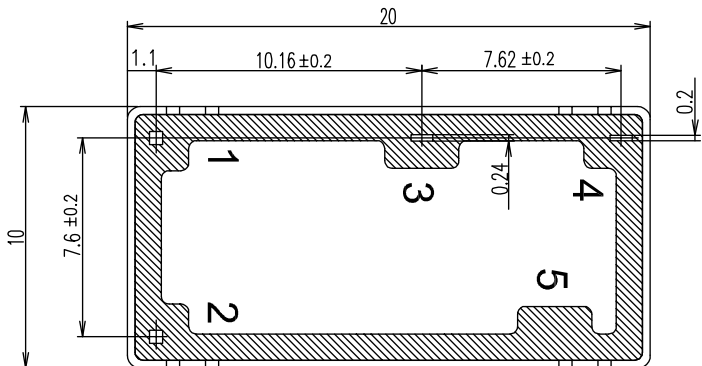
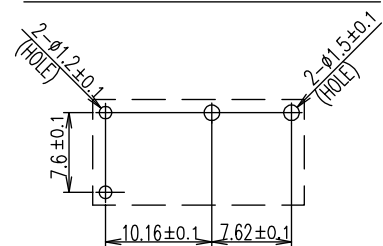

Diagram dimension	Tolerance
0.99mm max.	±0.1mm
1 - 2.99mm	±0.2mm
3mm min.	±0.3mm

THIS DRAWING IS A CONTROLLED DOCUMENT.		DWN	H.SASAKI		TE Connectivity
DIMENSIONS: mm		CHK	N.FUNAYAMA		
TOLERANCES UNLESS OTHERWISE SPECIFIED:		APVD	A.NAGAI		NAME
0 PLC ±- 1 PLC ±- 2 PLC ±- 3 PLC ±- 4 PLC ±- ANGLES ±-		PRODUCT SPEC	SEE PRODUCT SPEC		PCH-D2M CUSTOMER DRAWING
MATERIAL		FINISH	APPLICATION SPEC	-	RESTRICTED TO
-		-	WEIGHT	-	SIZE
			A3	00779	CAGE CODE
				1461350	DRAWING NO
					RESTRICTED TO
					SCALE
					5:1
					SHEET
					1 of 2
					REV
					G

THIS DRAWING IS UNPUBLISHED. RELEASED FOR PUBLICATION
 © COPYRIGHT - By - ALL RIGHTS RESERVED.

LOC	DIST	REVISIONS					
HB	-	P	LTR	DESCRIPTION	DATE	DWN	APVD
		-		SEE SHEET 1	-	-	-

1461350-7	PCH-148D2M	108-79650	48V	PCH-148D2M	g
1461350-6	PCH-124D2M	108-79649	24V	PCH-124D2M	f
1461350-5	PCH-112D2M	108-79648	12V	PCH-112D2M	e
1461350-4	PCH-109D2M	108-79647	9V	PCH-109D2M	d
1461350-3	PCH-106D2M	108-79646	6V	PCH-106D2M	c
1461350-2	PCH-105D2M	108-79645	5V	PCH-105D2M	b
1461350-1	PCH-103D2M	108-79644	3V	PCH-103D2M	a
TE PART NO	TE TYPE NAME	PRODUCT SPEC	PART B	PART A	TYPE

RELAY TYPE

NOTES:

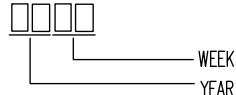
- 1.LAST SUFFIX NON : WASHABLE TYPE
- ② 2.LOT NO. SYSTEM AS FOLLOWING:

- ③ 3.TERMINAL DIMENSION IS BEFORE SOLDER DIP;
- ④ 4.FOR THE TIN-PLATING OF THE PINS:
 +0.1mm FOR WIDTH,THICKENSS AND DIAMETER.
 +0.5mm FOR LENGTH.
- ⑤ 5.MARKING FROM INK TO LASER.
- ⑥ 6.ADD LOT NO. SYSTEM AS FOLLOWING;

 - I, DIGITS FOR DAY OF THE WEEK
 1...MONDAY IN THIS WEEK;
 2...TUESDAY IN THIS WEEK;
 3...WEDNESDAY IN THIS WEEK;
 4...THURSDAY IN THIS WEEK;
 5...FRIDAY IN THIS WEEK;
 6...SATURDAY IN THIS WEEK;
 7...SUNDAY IN THIS WEEK
 - II, DIGITS FOR SHIFT OF THE DAY
 1...DAY SHIFT IN THIS DAY;
 2...NIGHT SHIFT IN THIS DAY;
 - III, ONE CHARACTER DISTINGUISH THE LINE IDENTITY, SUCH AS: A,B,....Z

		EPOXY RESIN	SEAL	15
CLASS E		UEW	MAGNETIC WIRE	14
	SOLDER DIP	CP WIRE	COIL TERMINAL	13
		Ag ALLOY	STATONARY CONTACT	12
		Ag ALLOY	MOVABLE CONTACT	11
		Cu ALLOY	HINGE SPRING	10
	SOLDER DIP	Cu ALLOY	NO TERMINAL	9
	SOLDER DIP	Cu ALLOY	MOVABLE SPRING	8
UL 94V-0		PA NYLON	CARD	7
UL 94V-0		PBT	CASE	6
UL 94HB		PA NYLON	BOBBIN	5
UL 94V-0		PBT	BASE	4
		Ni PLATED	STEEL CORE	3
		CuNi PLATED	STEEL ARMATURE	2
		CuNi PLATED	STEEL YOKE	1
INCOMBUSTIBILITY	TREATMENT	MATERIAL	DESCRIPTION	ITEM

THIS DRAWING IS A CONTROLLED DOCUMENT.		DWN	H.SASAKI	
DIMENSIONS: mm		CHK	N.FUNAYAMA	
TOLERANCES UNLESS OTHERWISE SPECIFIED:		APVD	A.NAGAI	
0 PLC ± -		PRODUCT SPEC	SEE PRODUCT SPEC	
1 PLC ± -		APPLICATION SPEC	-	
2 PLC ± -		WEIGHT	-	
3 PLC ± -		CUSTOMER DRAWING		
4 PLC ± -		SIZE	A3	
ANGLES ± -		CAGE CODE	00779	
FINISH		DRAWING NO	C=1461350	
-		RESTRICTED TO	-	
-		SCALE	5:1	
-		SHEET	2 of 2	
-		REV	G	



PCH-D2M CUSTOMER DRAWING